

MultiGrip

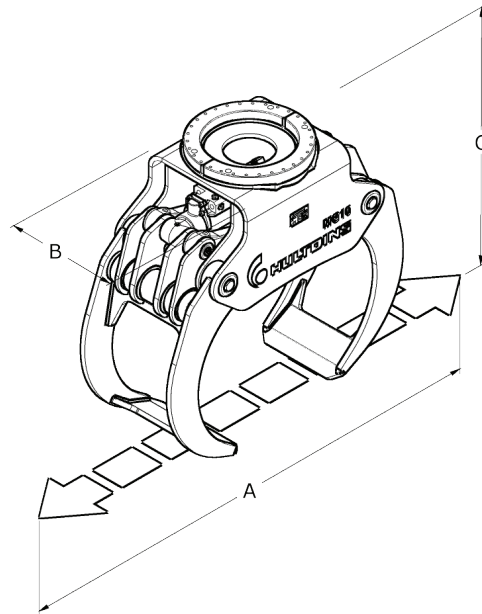

MG / Rotator

Product features

- Flexible bypass arm design for variety of grapple work
- High strength robotic welded construction throughout
- Cushioned cylinder for reduced shock load
- Cylinder load check and accumulator standard for maximum safety
- Tapered sleeve pin design eliminates any joint motion
- Includes load-check valve and accumulator for maximal safety
- Dual solid cast steel push rods for balance design and strength
- XR low profile Rotator with very high torque and load capacity
- Rotator is a complete, sealed solution with patented load transmission
- Excavator mounts available for direct boom mount or to match machine coupler

MG			MG12		MG16		MG20	
Suitable machine weight	metric tons		8-10		12-16		18-24	
Weight excl. rotator	lb	(kg)	667	(303)	1 005	(457)	1 221	(555)
Max. load	lb	(kg)	13 200	(6 000)	17600	(8 000)	22 000	(10 000)
Grapple area, tip - tip	ft ²	(m ²)	2.80	(0.26)	3.87	(0.36)	5.59	(0.52)
Max. gripping width "A"	inches	(mm)	58.89	(1 496)	71.73	(1 822)	89.72	(2 279)
Max. width "B"	inches	(mm)	17.87	(454)	20.90	(531)	20.90	(531)
Min. gripping diameter	inches	(mm)	3.23	(82)	3.70	(94)	7.00	(178)
Height, arms tip - tip "C"	inches	(mm)	35.87	(911)	40.04	(1 017)	47.67	(1 211)
Max. operating pressure	psi	(MPa)	3625	(25)	3625	(25)	3625	(25)
Gripping force, arms tip-tip, at 3625 psi	lbf	(kN)	3373	(15)	4272	(19)	5172	(23)
Recommended rotator	Model		XR300		XR400		XR400 XR500	



Hultdins Inc.
 22 Morton Avenue East, Brantford,
 Ontario, Canada N3R 7J7
 Ph (519) 754-0044, Fax (519) 754-1569
 E-mail: info@hultdins.com
www.hultdins.com
 With reservation for possible changes and any inaccuracies.